

# **System Architecture Views**

Compiled by David Keener

Created: 11/30/17

Last Updated: 02/15/18

# Disclaimer

The charts and diagrams collected in this presentation were gathered from all around the Web and were created by a diverse set of individuals and organizations.

The content was gathered to serve as a sort of “Cheat Sheet” on how to create the Operational Viewpoint (OV) and Systems Viewpoint (SV) diagrams mandated by DODAF 2.0, the DoD Architecture Framework 2.0. Numerous examples of each type of diagram are provided.

The presentation is provided gratis to the community to promote the noble cause of quality enterprise architecture.

Where needed, some commentary is provided in red.

# Contents

- Disclaimer
- General Overview
- Operational Viewpoint
- Systems Viewpoint
- References

# General Overview

## Basic Principles - Graphic, Textual, and Tabular Products

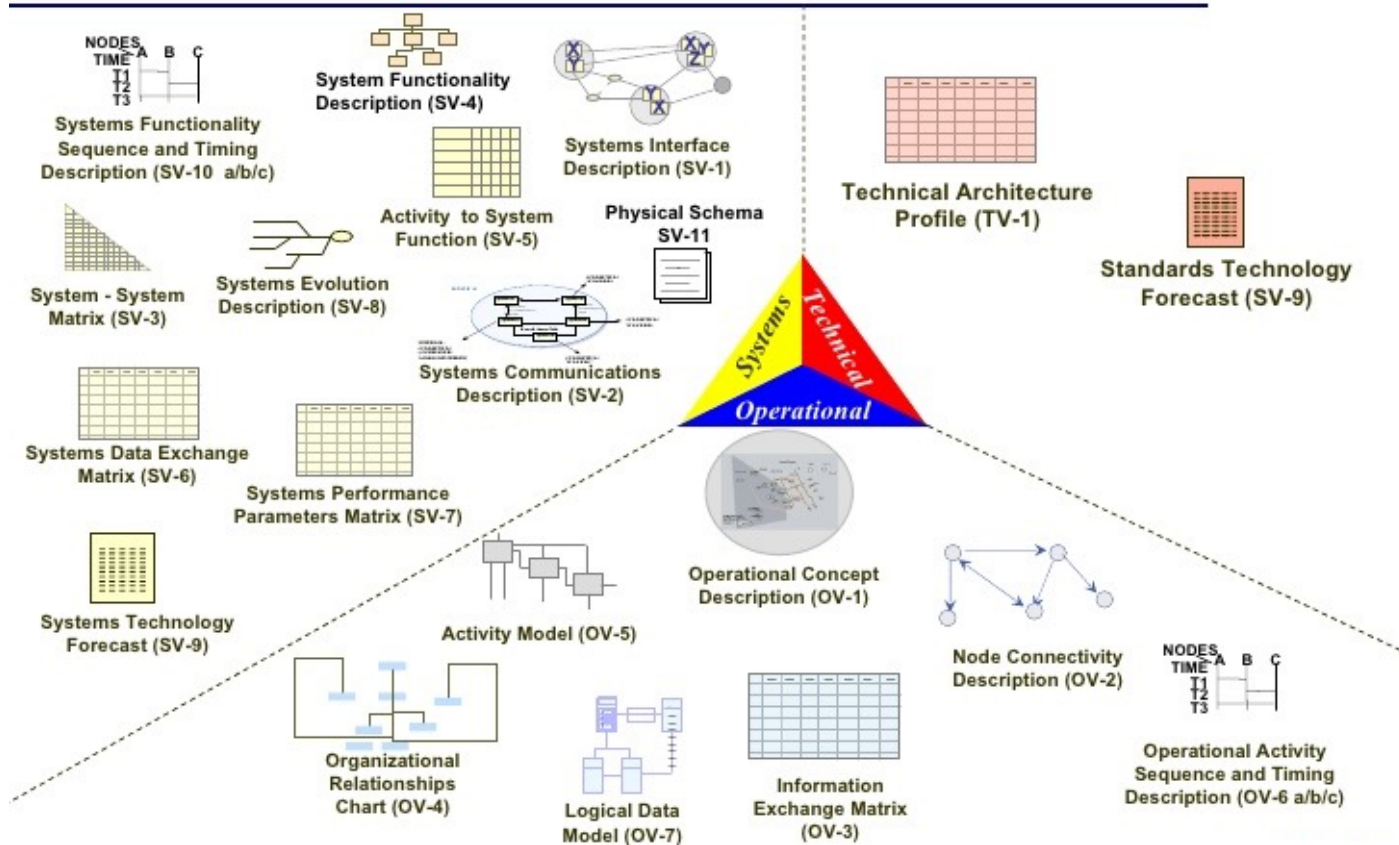

# Core Products

## The Core Products Link to Each Other

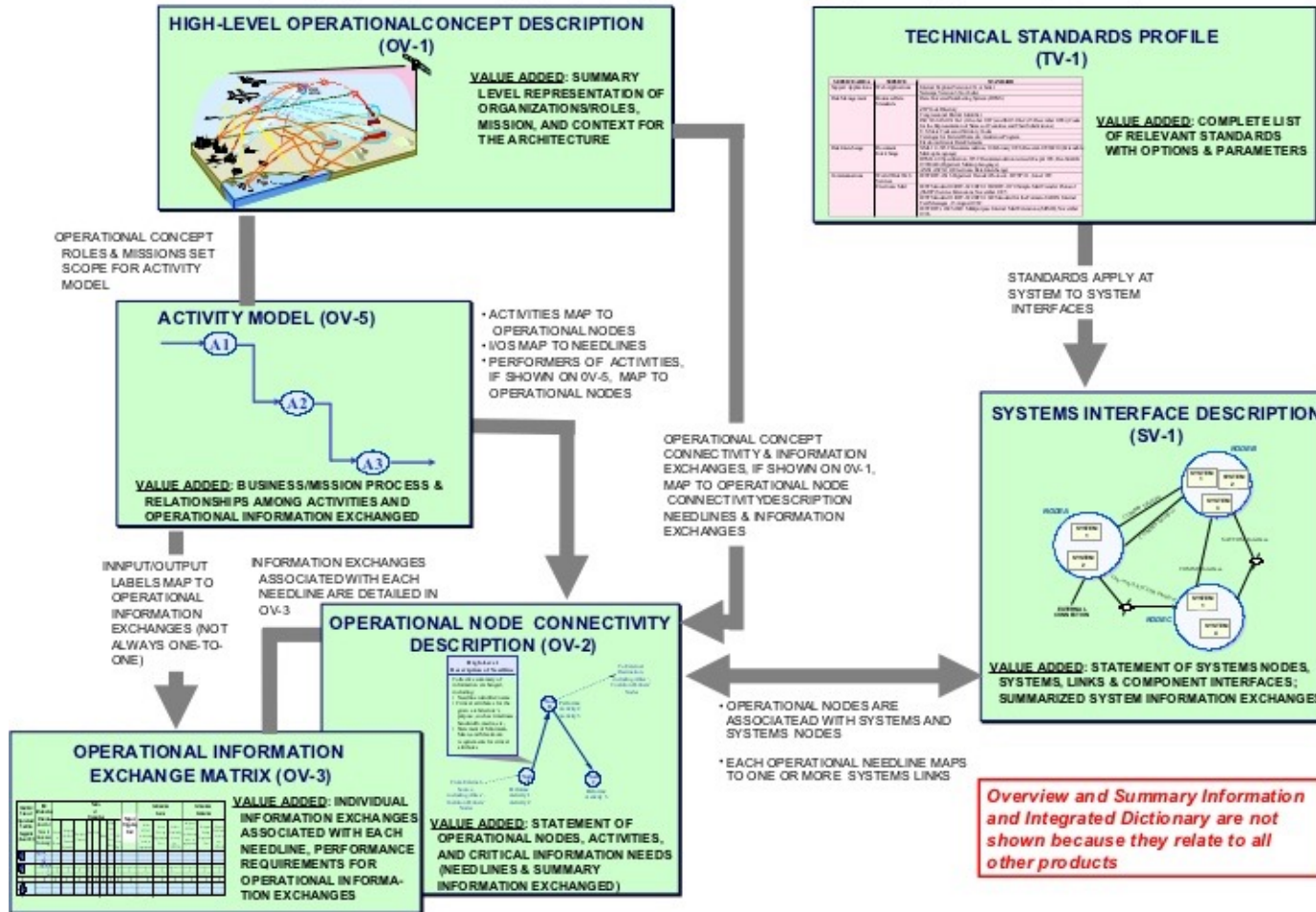

# OV-3, SV-1 and SV-6

## Some Other Important Product Linkages

### OV-3 Operational Information Exchange Matrix

Identify Name of Operational Needline from OV-2	Identify Name of Information Exchange	Type of Information										Identify Name of Information Exchange	Identify Name of Information Exchange
		Content	Size	Media	Format	Protocol Used	LI&I Level Achievable	ID of Source System	Source System Function (from S.d.)	Operational Mode(s) Where System Is Resident	ID of Receiving System		
Needline 1	...	...	...	...	...	...	...	...	...	...	...	...	...
Needline 2	...	...	...	...	...	...	...	...	...	...	...	...	...
Needline n	...	...	...	...	...	...	...	...	...	...	...	...	...

1

Each needline is decomposed into one or more system interfaces ...

### SV-1 System Interface Description

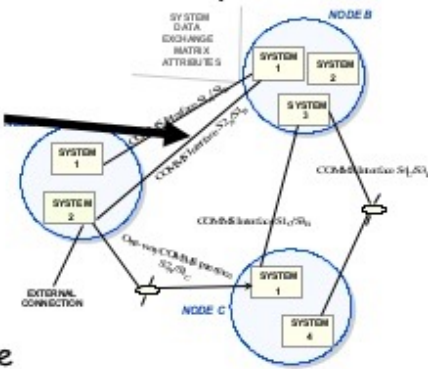

2

...The individual information exchanges are assigned to the appropriate system interface...

3

...And the sending and receiving systems used to implement the interface are indicated...

Identify Name of Operational Needline Supported (from OV-2)	Identifier/ Name of Corresponding System Interface(s) (from SV-1)	Identifier/ Name of Operational Information Exchange Supported (from OV-3)	Nature of Transaction						Data Source			Data Destination		
			Content	Size	Media	Format	Protocol Used	LI&I Level Achievable	ID of Source System	Source System Function (from S.d.)	Operational Mode(s) Where System Is Resident	ID of Receiving System	Receiving System Function (from S.d.)	Operational Mode(s) Where System Is Resident
Needline 1	e.g. Interface 1	e.g. I.e. 1.a, 1.b, 1.c												
	e.g. Interface 2	e.g. I.e. 1.d, 1.e, 1.f												
Needline 2														
Needline n														

SV-6 System Data Exchange Matrix

# **Operational Viewpoint**

# OV View Development

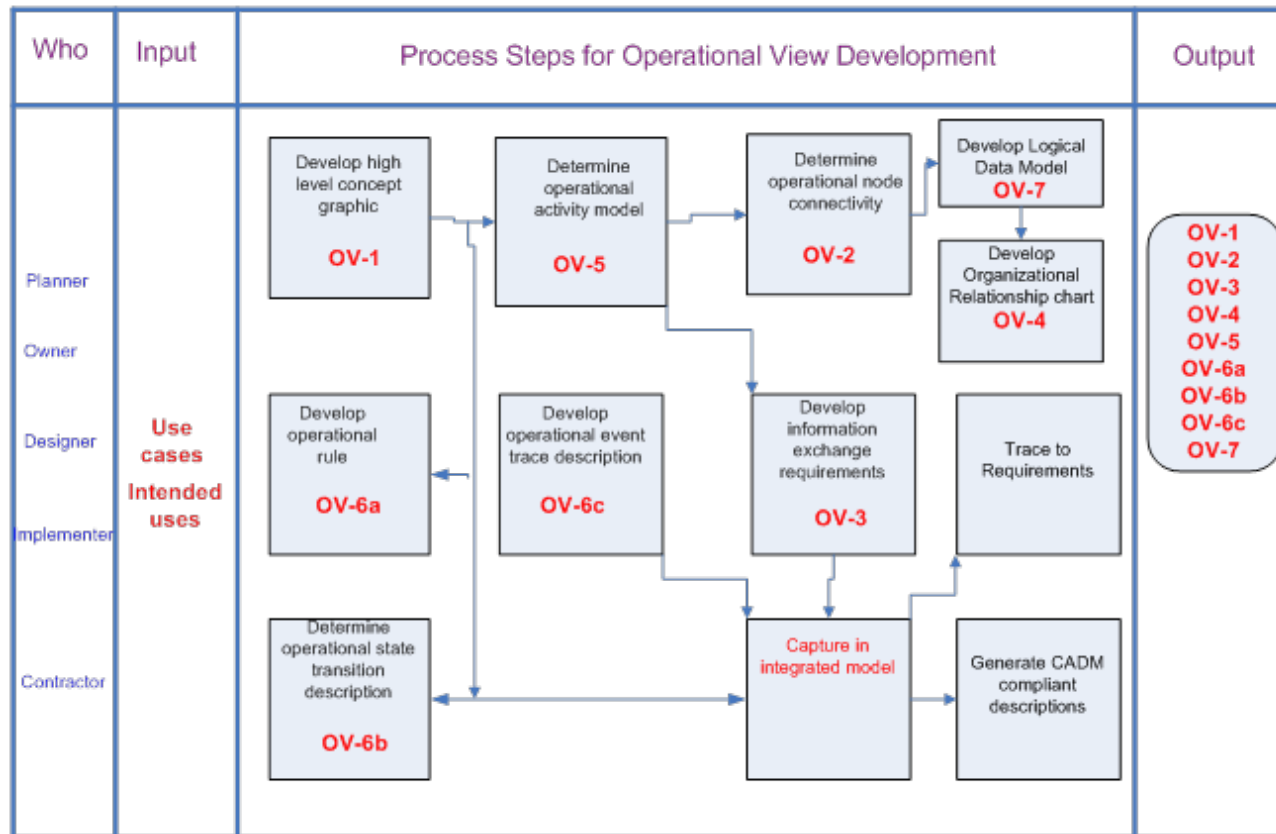



# Overview of Core OV Views 2

## Operational View Captures Critical Mission Relationships and Information Exchanges

### High-Level Operational Concept Description



High-level graphical description of the operational concept of interest

### Operational Node Connectivity Description

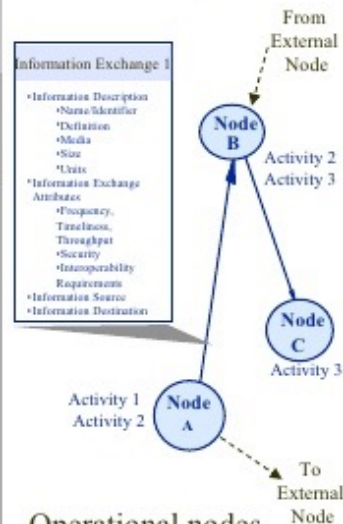

Operational nodes, activities performed at each node, node-to-node relationships, and information needlines

### Operational Activity Model

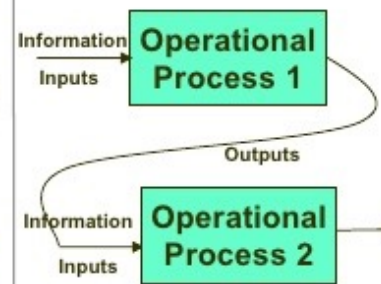

Operational activities, information inputs and outputs, conditions

### Operational Information Exchange Matrix

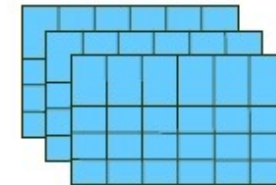

Summary of Information exchanged between nodes with attributes, such as security, timeliness



# OV-1 Example 2

## High-Level Operational Concept Graphics

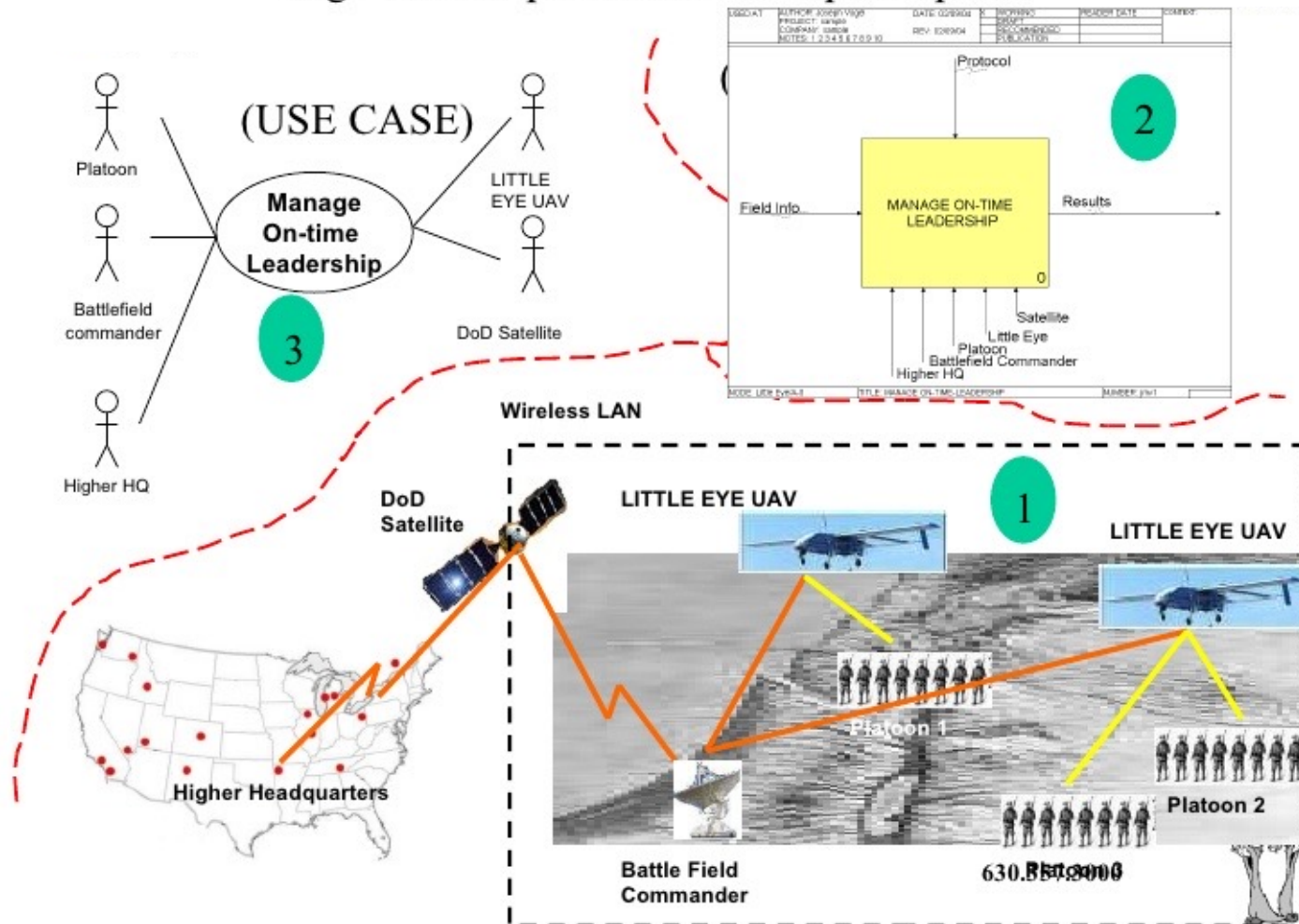

# OV-1 Example 3

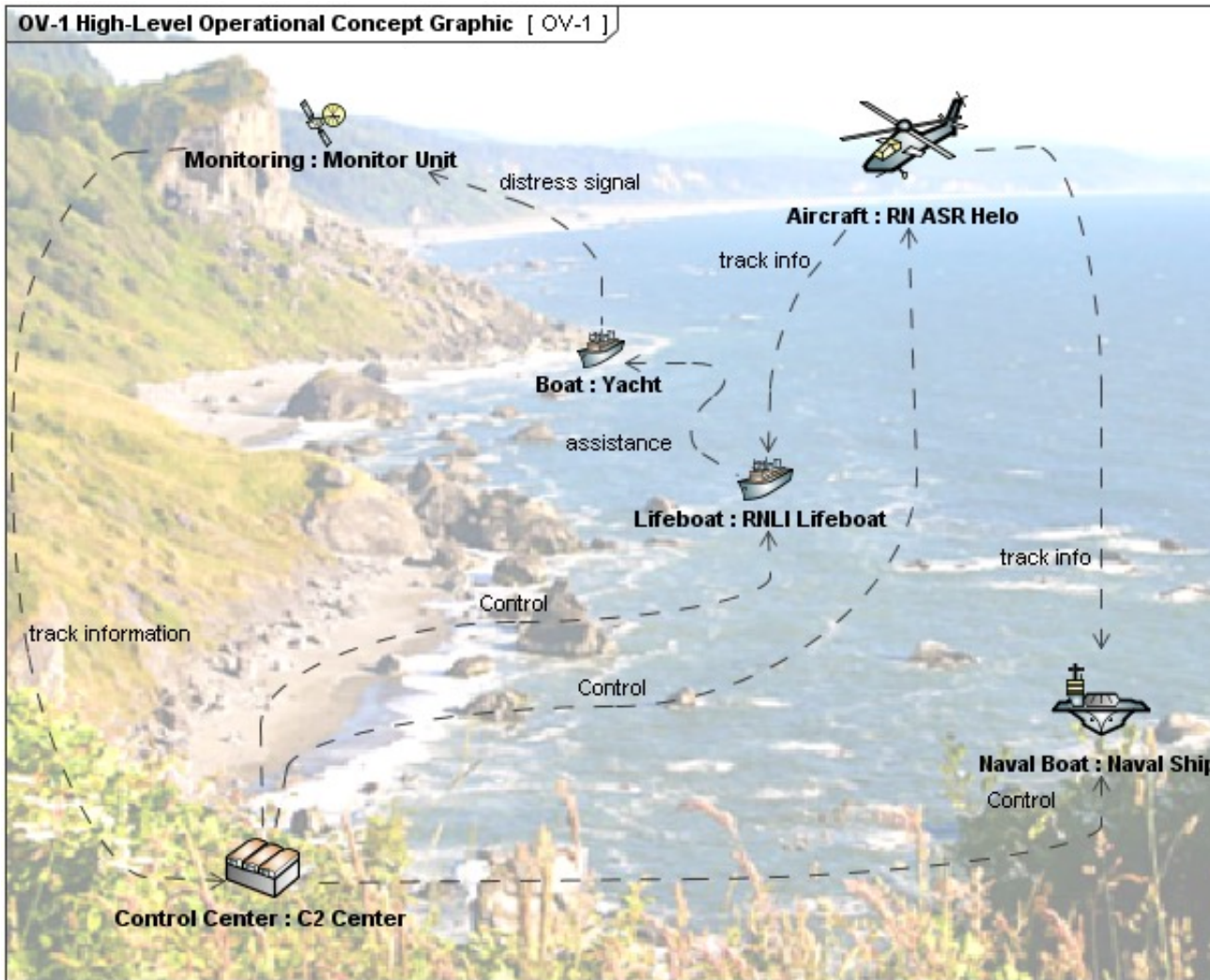

# OV-1 Example 4

## High Level Operational Concept (OV-1)

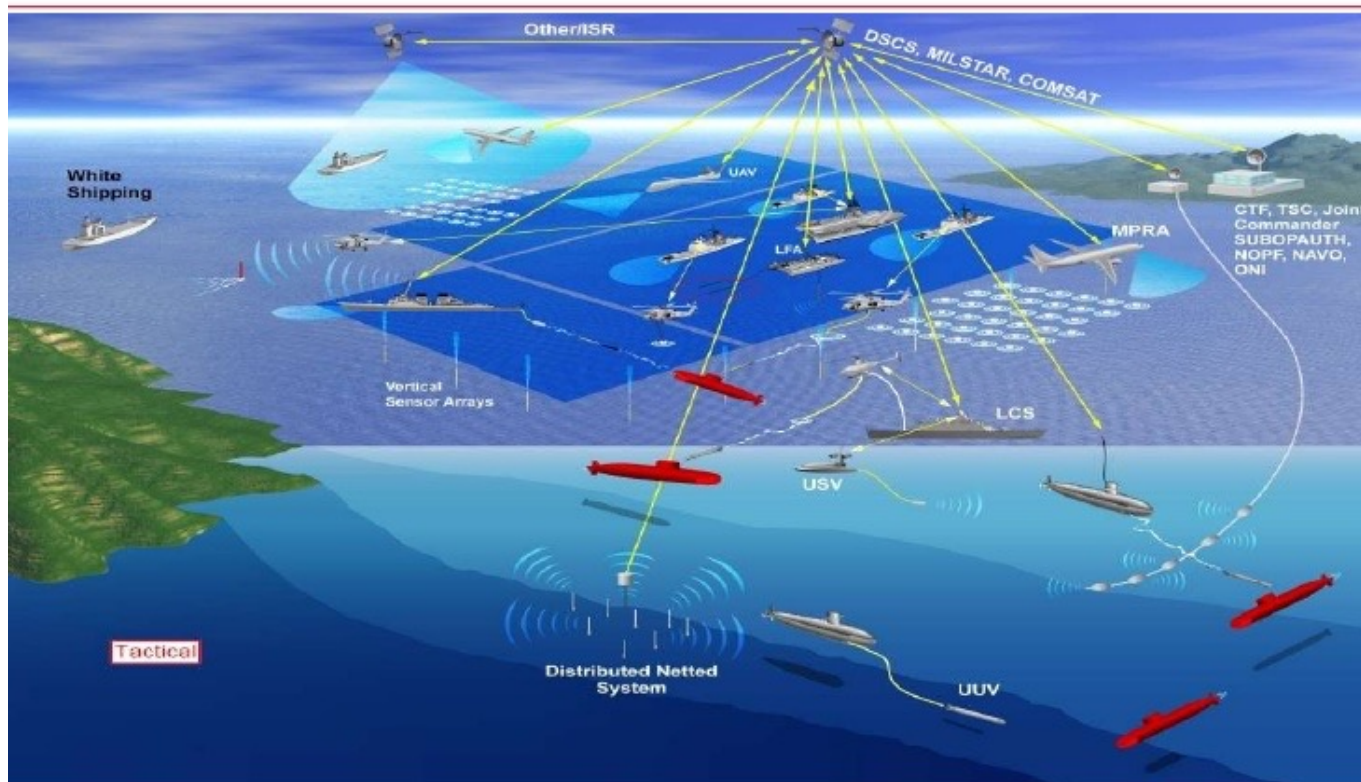

# OV-1 Example 5

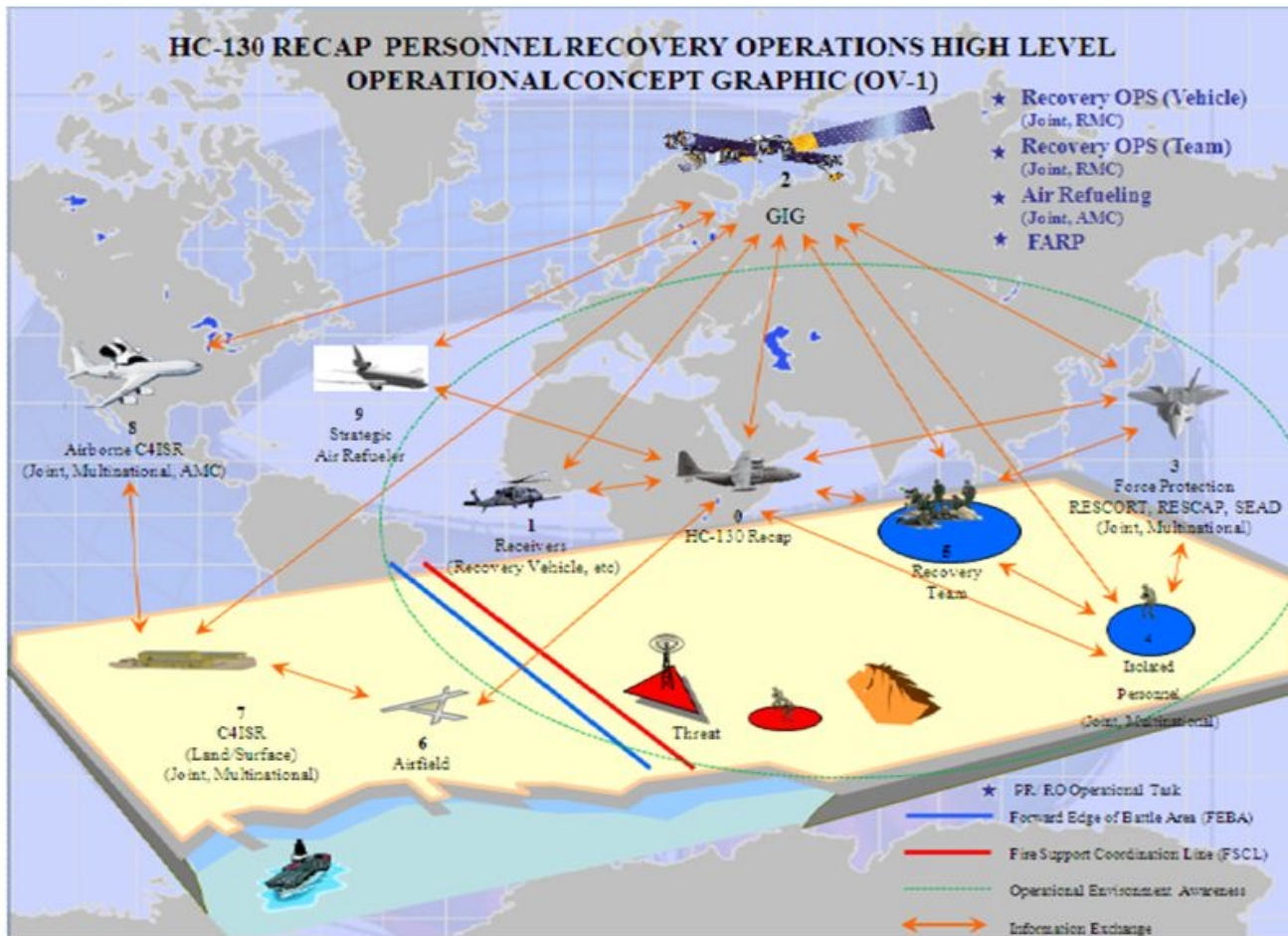

# OV-2 Example 1

## Operational Node Connectivity Description

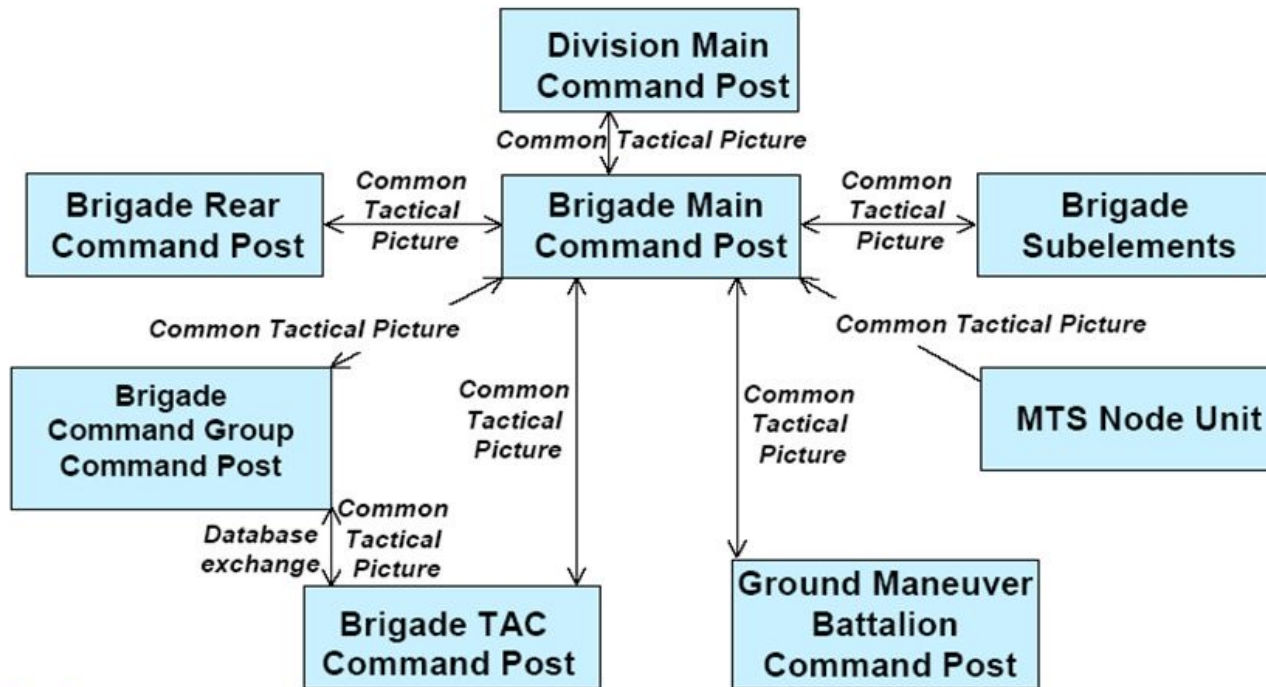

- Nodes show who communicates with whom
- Needlines show WHAT is communicated.



# OV-2 Example 2

## A Closer Look at the Operational Node Connectivity Description OV-2

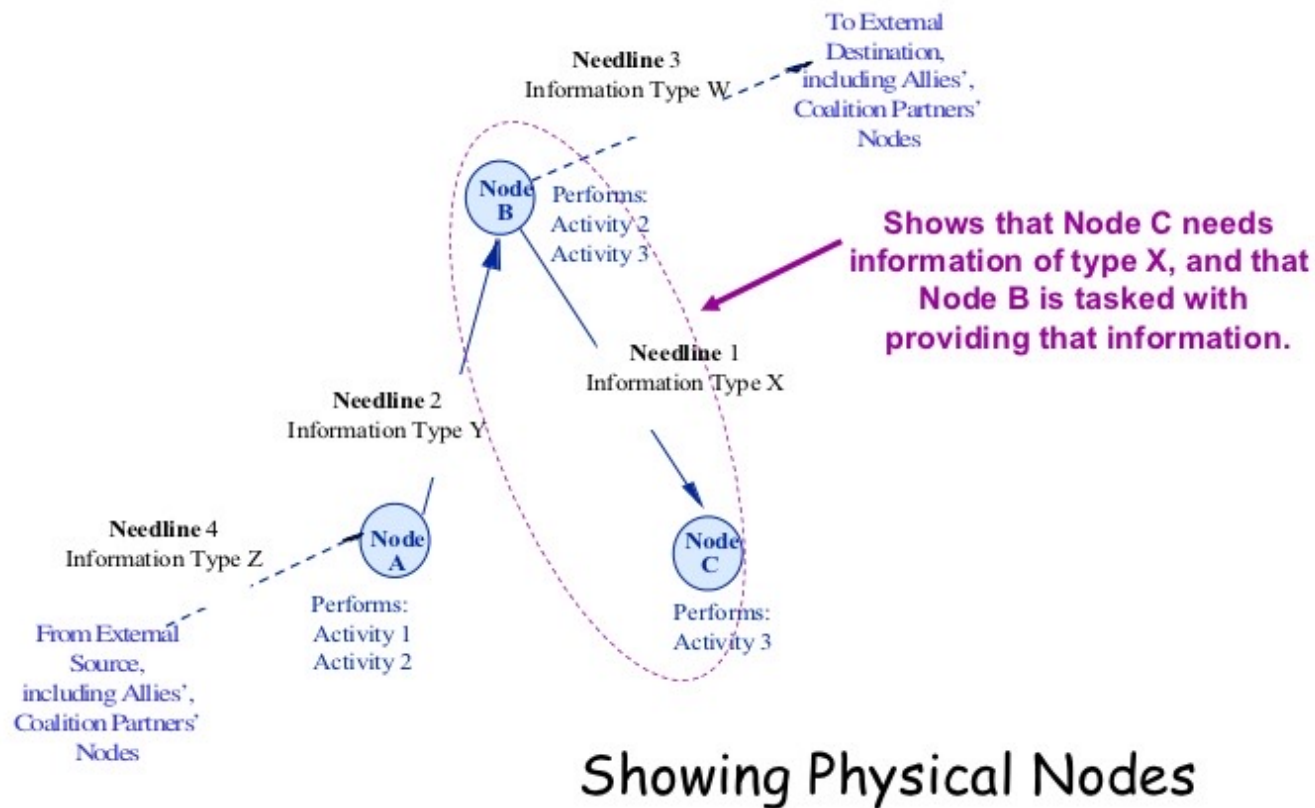

# OV-2 Example 3

## Operational Node Connectivity Description (OV-2)

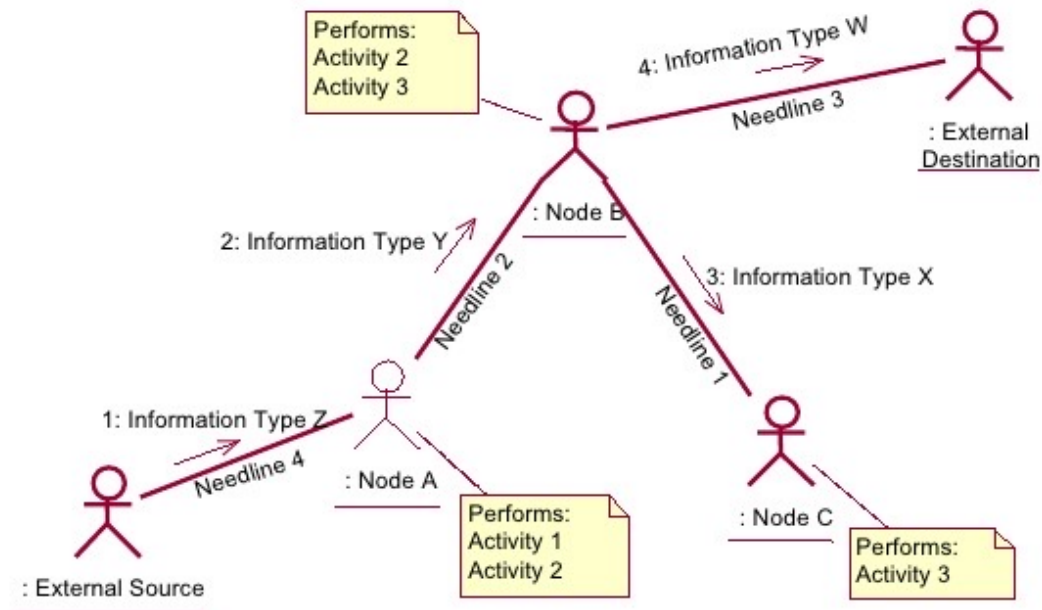

# OV-3 Example 1

## A Closer Look at the Operational Information Exchange Matrix OV-3

For each needline ... There is a listing of distinct information exchanges ... And their attributes

* Identifier/ Name of Operational Needline Supported (from OV-2)	* Identifier/ Name of Information Exchange	Nature of Transition							* Purpose/ Triggering Event	Information Source		Information Destination	
		* Mission Scenarios	* Language (For Multi- National Operations)	* Description (Content)	* Sub-Units	* Media	* Collaborative (Y/N/P)	* LISI Level Required		* ID of Producing Node (facility or logical node)	* ID/Name of Producing Activity	* ID/ Name of Receiving Node (facility or logical node)	* ID/Name of Receiving Activity
1	e.g., 1-a 1-b 1-n												
2	e.g., 2-a 2-b 2-n												
⋮	⋮	⋮	⋮	⋮	⋮	⋮	⋮	⋮	⋮	⋮	⋮	⋮	
n													

C  
O  
N  
T  
I  
N  
U  
E  
D

* Identifier/ Name of Operational Needline Supported (from OV-2)	* Identifier/ Name of Information Exchange	Performance Attributes			Information Assurance Attributes				Threats			Physical Environment			Remarks/ Other
		* Frequency	* Timeliness	* Throughput	* Security Classification (& Declassification/ Restrictions, if app.)	* Priority or Criticality	* Integrity Checks Required	* Assured Authorization to Send/ Receive	* Physical (includes weather, terrain)	* Electronic (jamming, hackers, etc.)	* Political/ Economic	* Aerospace	* Land	* Sea	
1	e.g., 1-a 1-b 1-n														
2	e.g., 2-a 2-b 2-n														
⋮	⋮	⋮	⋮	⋮	⋮	⋮	⋮	⋮	⋮	⋮	⋮	⋮	⋮	⋮	⋮
n															

\* Indicates minimum required entries

# OV-3 Example 2

## OV-3 – Operational Information Exchange Matrix

Needline Identifier	Information Exchange Identifier	Information Element Description					Producer		Consumer	
		Information Element Name and Identifier	Content	Scope	Accuracy	Language	Sending Op Node Name and Identifier	Sending Op Activity Name and Identifier	Receiving Op Node Name and Identifier	Receiving Op Activity Name and Identifier

Needline Identifier	Information Exchange Identifier	Nature of Transaction				Performance Attributes		Information Assurance			Security						
		Mission/Scenario UJTL or METL	Transaction Type	Triggering Event	Interoperability Level Required	Criticality	Periodicity	Timeliness	Access Control	Availability	Confidentiality	Dissemination Control	Integrity	Accountability	Protection (Type Name, Duration, Date)	Classification	Classification Caveat

# OV-4 Example 1

## OV-4 Organizational Relationships Chart

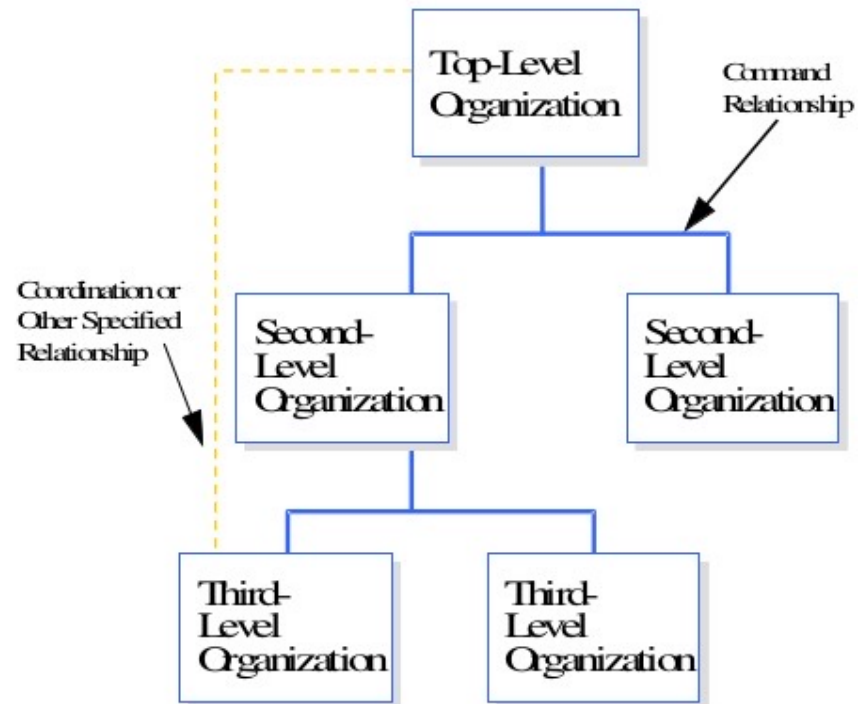

# OV-4 Example 2

## Organizational Relationships Chart (OV-4)

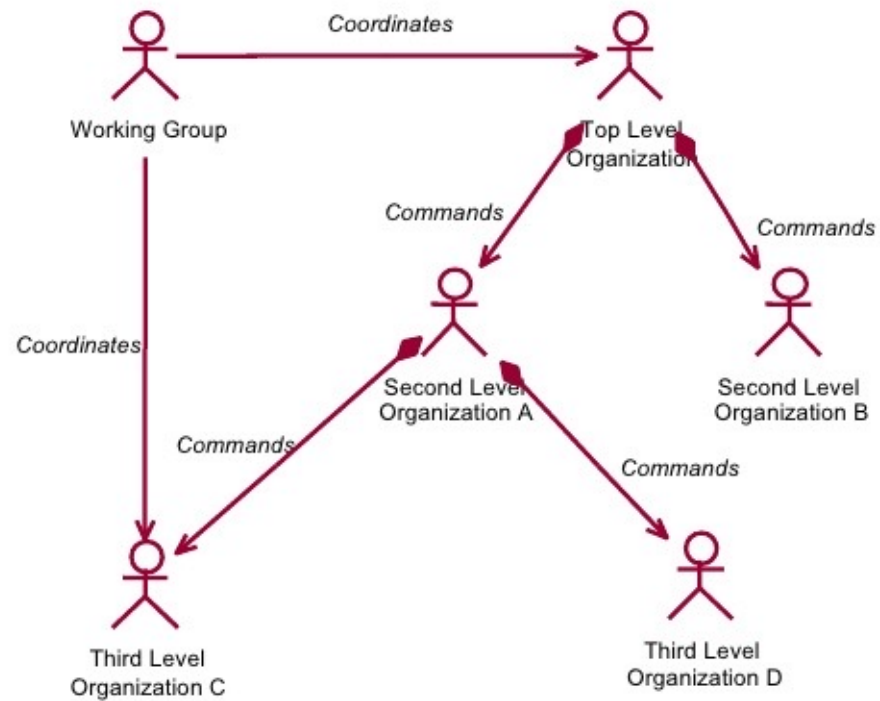

# OV-5a Example 1

Operation Activity Decomposition Diagram

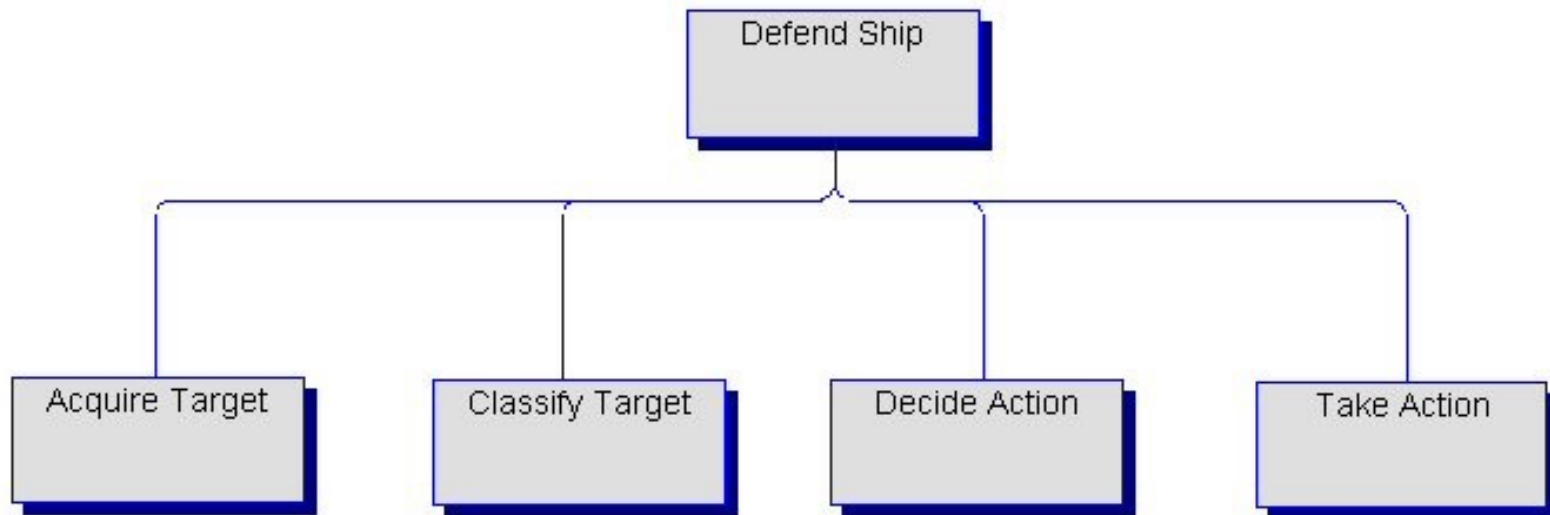

The OV-5a viewpoint ,the Operation Activity Decomposition Diagram, was added in DoDAF 2.0 in 2009 as a companion to the OV5b viewpoint, the Operational Activity Diagram. In DoDAF 1.5, the Operational Activity Diagram was simply referred to as the OV-5.

# OV-5b Example 1

## Operational Activity Model (OV-5)

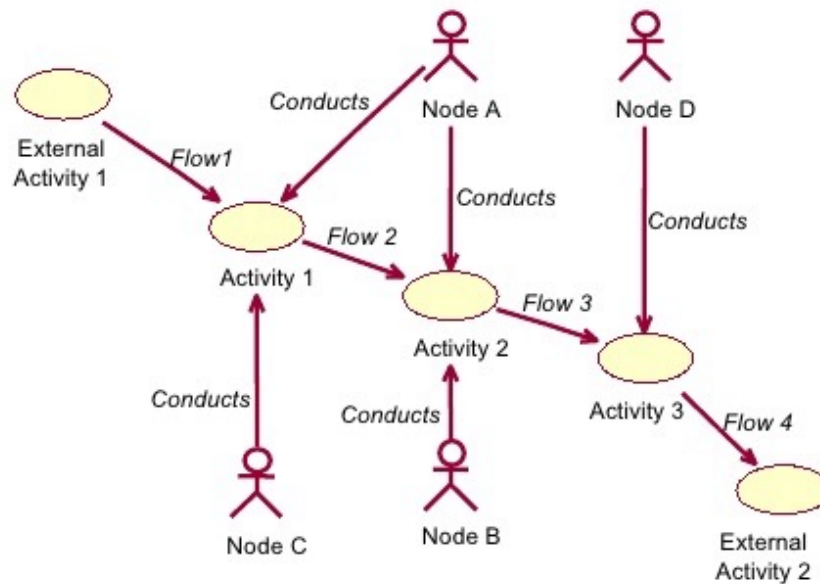

In DoDAF 1.5, OV-5 Diagrams were represented solely by the Operational Activity Model, shown in OV-5b Examples 1 – 3. In DODAF 2.0, this was separated into two diagrams: OV-5a, the Operational Decomposition Tree, and OV-5b, the Operational Activity Model.

# OV-5b Example 2

## Operational Activity Model (OV-5)

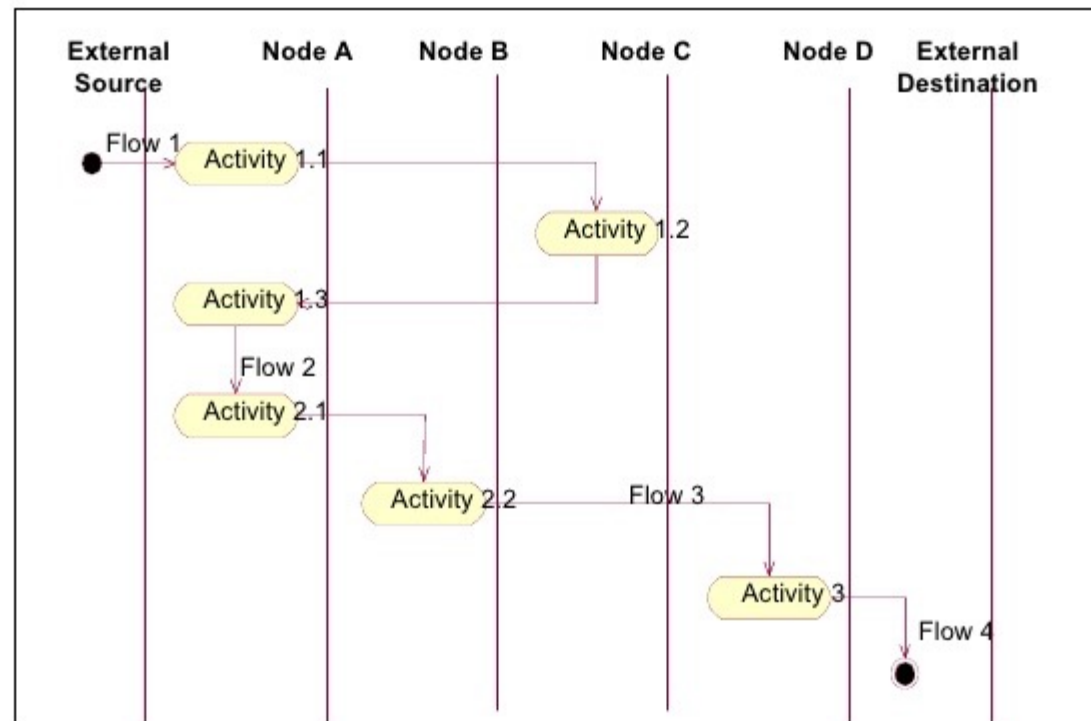

With OV-5b Diagrams, there are a number of different ways the data can be displayed. The important thing is effectively communicating the flow of the activities.





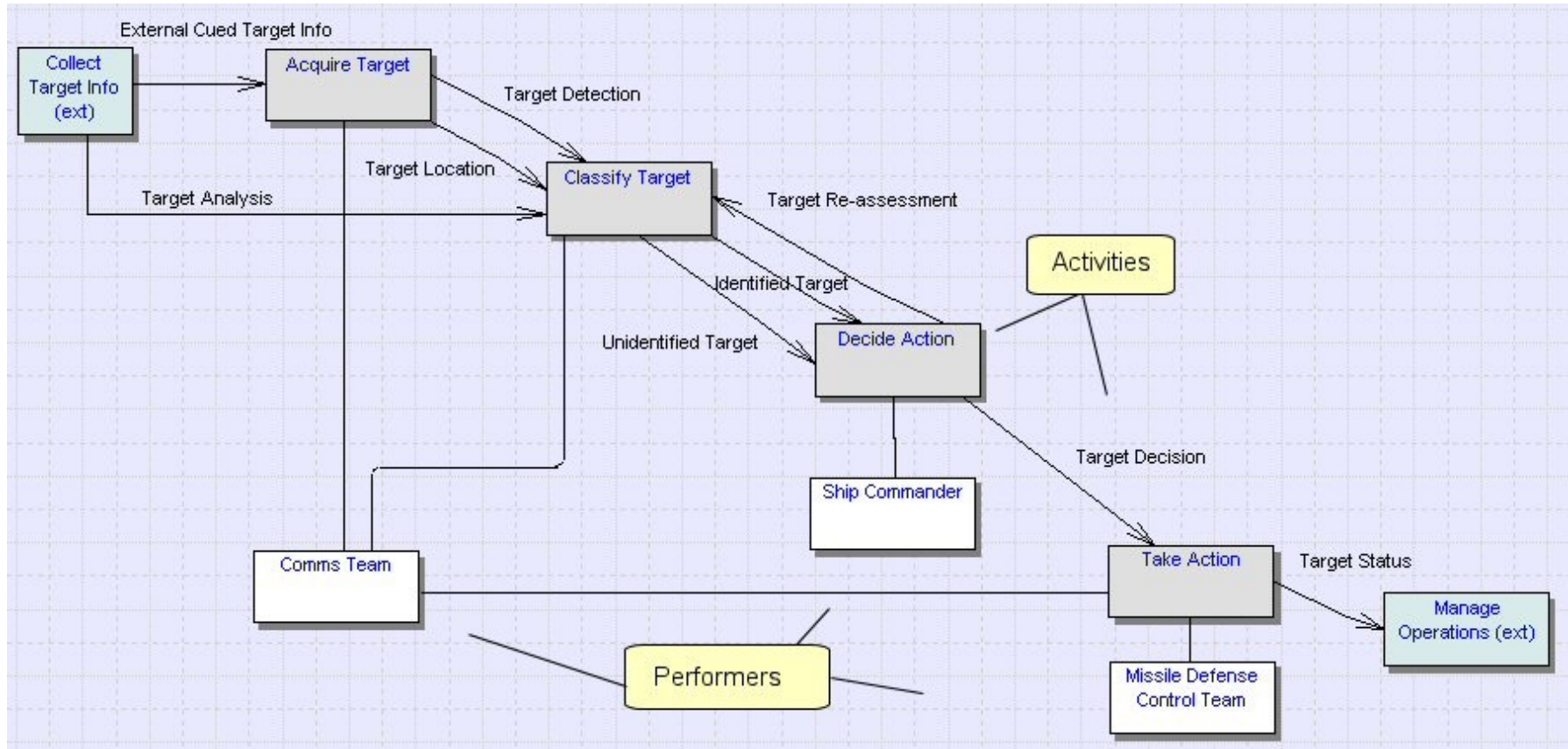





# OV-5b Example 3

## Operational Activity Model



# OV-6a Example 1

## Operational Rules Model

#	Applies To	Rule Specification	Rule Kind
1	 Search Node  Rescue Node  Monitoring Node	Respond to emergencies 24 hours a day	Constraint
2	 Rescue Node	Minimize the risk of pollution of the marine environment from ships	Constraint
3	 Rescue Node  Search Node	Where the coverage provided by military SAR assets meets the civil SAR requirement, they will be made available for civil aeronautical, maritime and land based SAR operations.	Constraint
4	 Monitoring Node  Search Node	The organization is based upon a continuous communications watch on VHF, VHF/DSC, MF and MF/DSC radio at 19 MRCC/MRSCs, which provide radio coverage of UK coastal and offshore waters out to 150 nautical miles.	Constraint
5	 Monitoring Node	Satellite communications extend coverage throughout the UKSRR and worldwide.	Constraint
6	 SAR Asset Control	SAR Operations are supported by a computerized command & control system, which provides incident management and recording; resource selection and alerting; logging and databases. A computerized system provides the facility to predict the movement of drifting targets at sea; produce search areas and optimum search coverage plans for search units.	Constraint

# OV-6a Example 2

## Operational Rules Model

<b>OV-6a: Operational Rules Model</b>	
<b>Communications Readiness Principle (CRP)</b>	
	CRP 01 - The GIG communications infrastructure shall support full IP convergence of traffic (voice, video, and data) on a single network.
<b>Communications Readiness Business Rules (CRR)</b>	
	CRR 01 - Implement a modular, layered design based on internet protocol for the transport infrastructure.
	CRR 02 - GIG communications systems shall provide network connectivity to end points (such as Wide and Local Area Networks and direct connections to mobile end-users) in the same or different autonomous systems.

- Same Principles and Rules from DoD IEA v1.2
- Operational rules derived from the GIG 2.0 ORA have been added

# OV-6a Example 3

## Operational Rules Model

BMD Active Defense

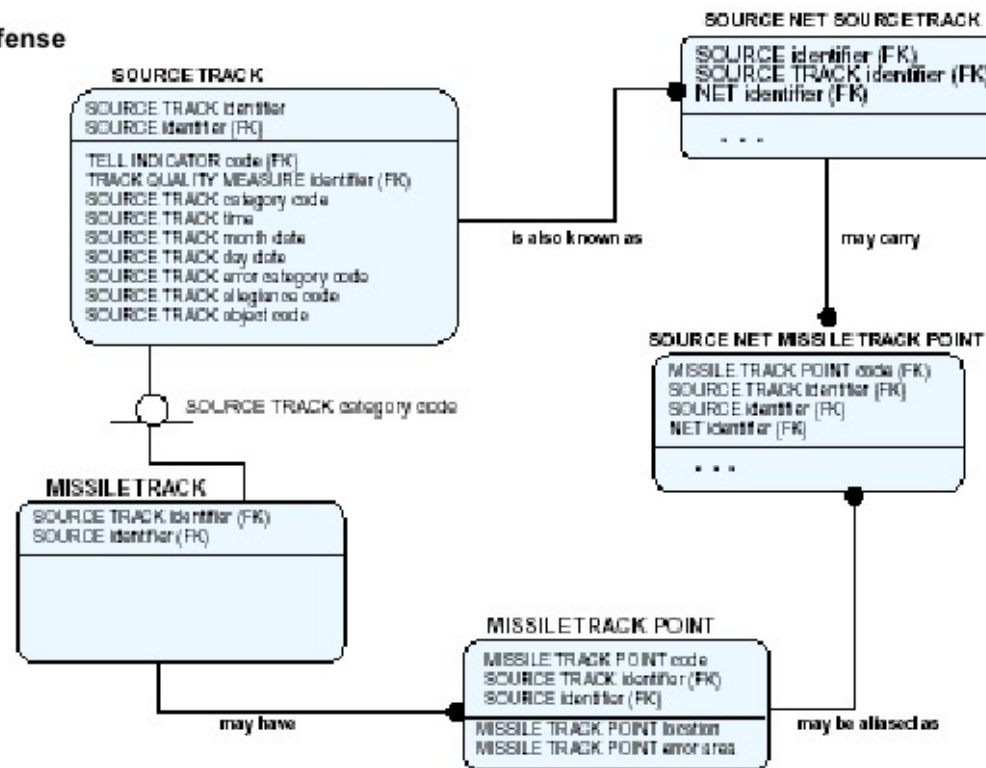

This is an unusual OV-6a; most diagrams of this type show rules in a tabular format, not a graphic format.

# OV-6b/6c Example 1/1

## OV-6 Operational Timing and Sequencing Products

OV-6a Operational Rules Model: no graphic

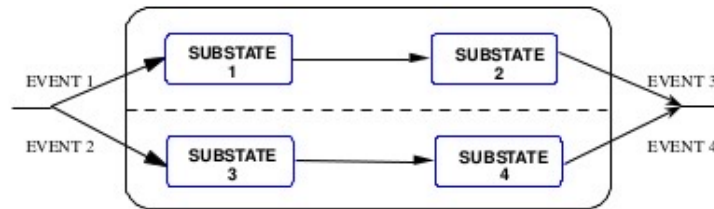

OV-6b Operational State Transition Description

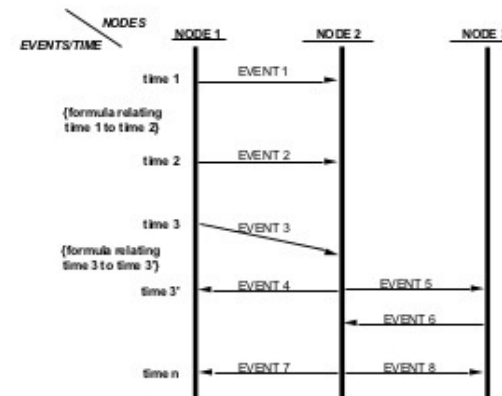

OV-6c Operational Event/Trace Description

# OV-6b Example 2

The Operational State Transition Description (OV-6b)



# OV-6c Example 2

## The Operational Event-Trace Description (OV-6c)

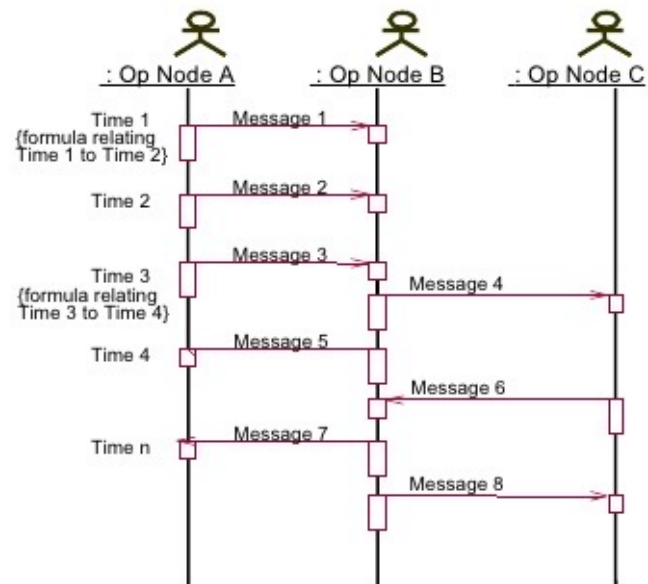

# OV-7 Example 1

## OV-7 Logical Data Model

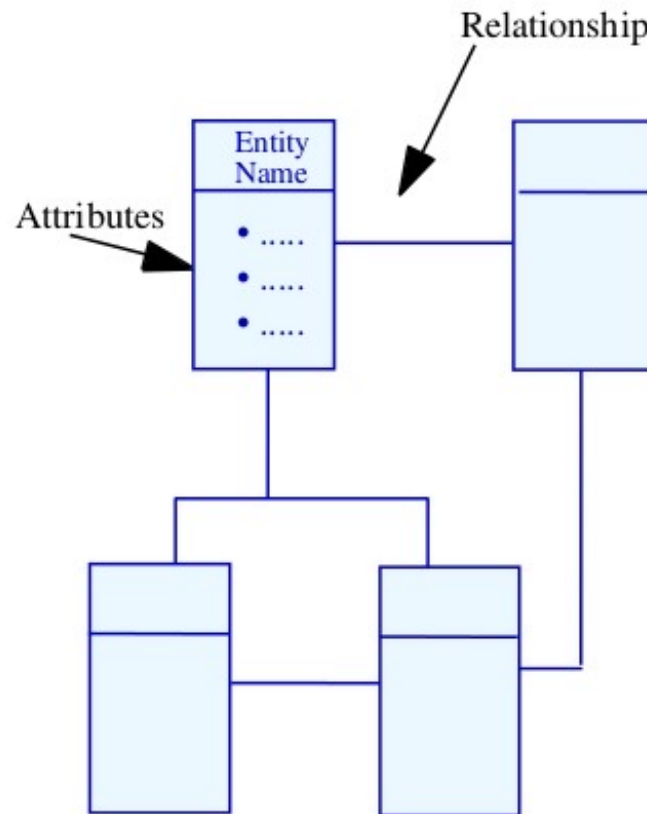

# OV-7 Example 2

## Logical Data Model (OV-7)

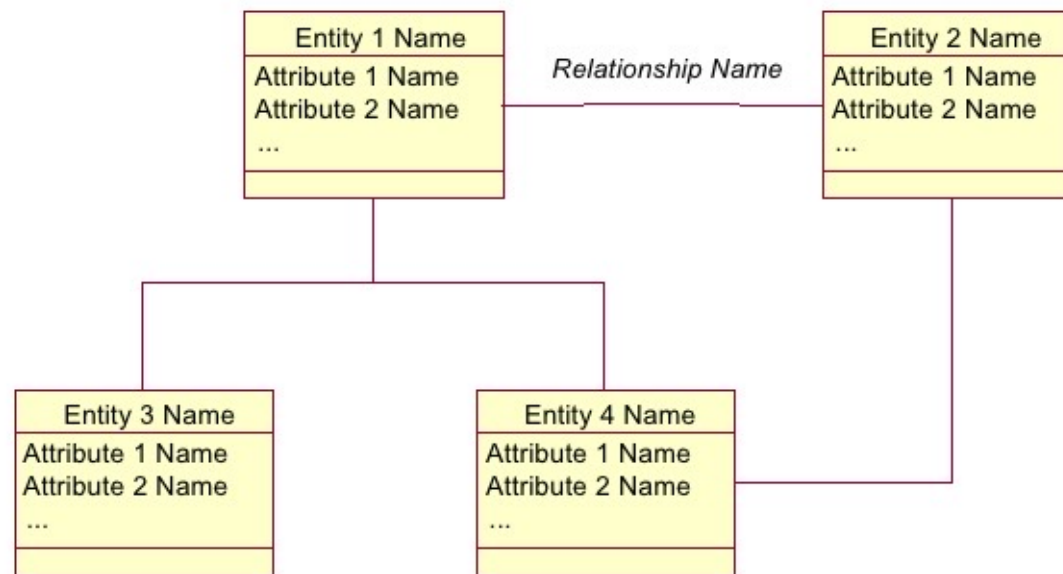

# **Systems Viewpoint**

# SV Core Overview

**Systems View Captures Systems, Functions Performed, Data, and Network Layout**

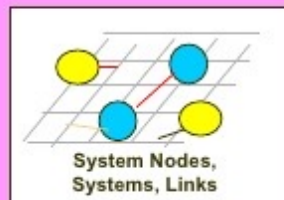

**Systems Interface Description SV-1**

Can include systems, H/W & S/W Items, Interfaces (conceptual), System Functions

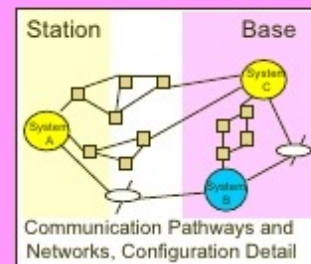

**Systems Communications Description SV-2**

Can include systems, communications nodes, networks, paths, Links forming path, protocols supported

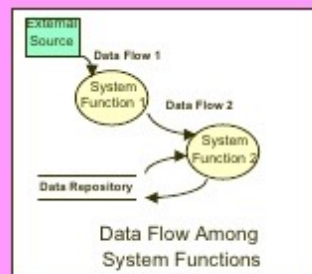

**Systems Functionality Description SV-4**

Includes data sources and sinks, repositories, data flows between system functions

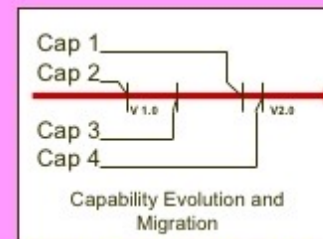

**Systems Evolution Description SV-8**

Describes planned systems evolution over time

# SV-1 Example 1

The Systems View Examines Current and Postulated IS Capabilities in Context with Mission Operations

Core Product: System Interface Description

Internodal

Node-Edge-to-Node-Edge

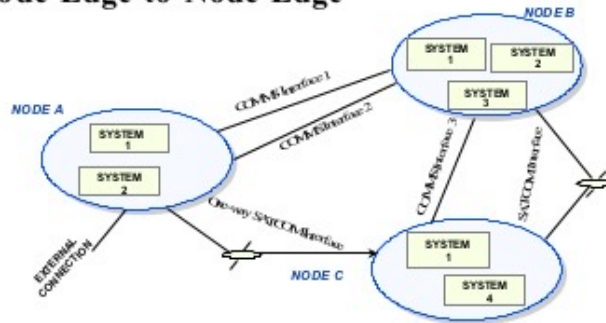

Internodal

System-to-System

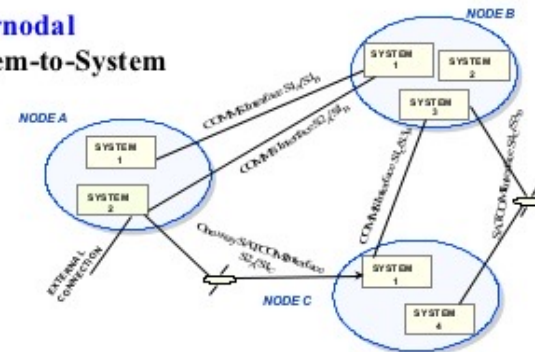

Intranodal

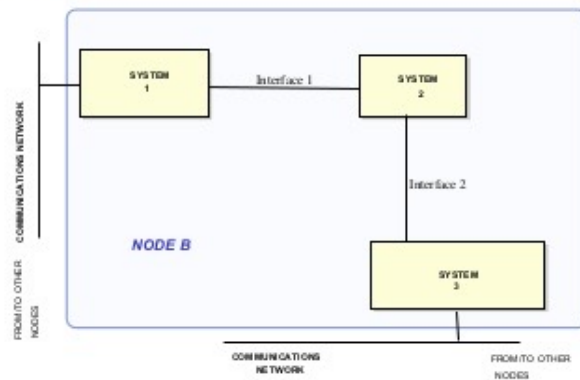

Intrasystem

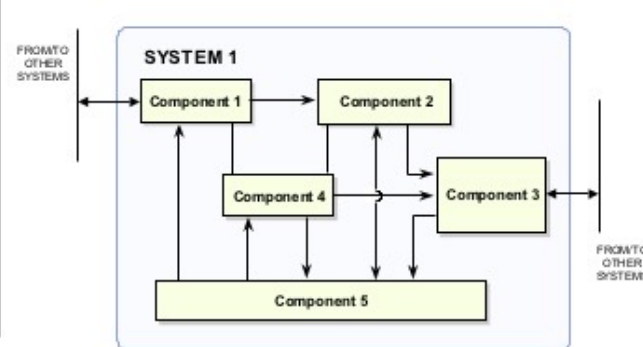

# SV-1 Example 2

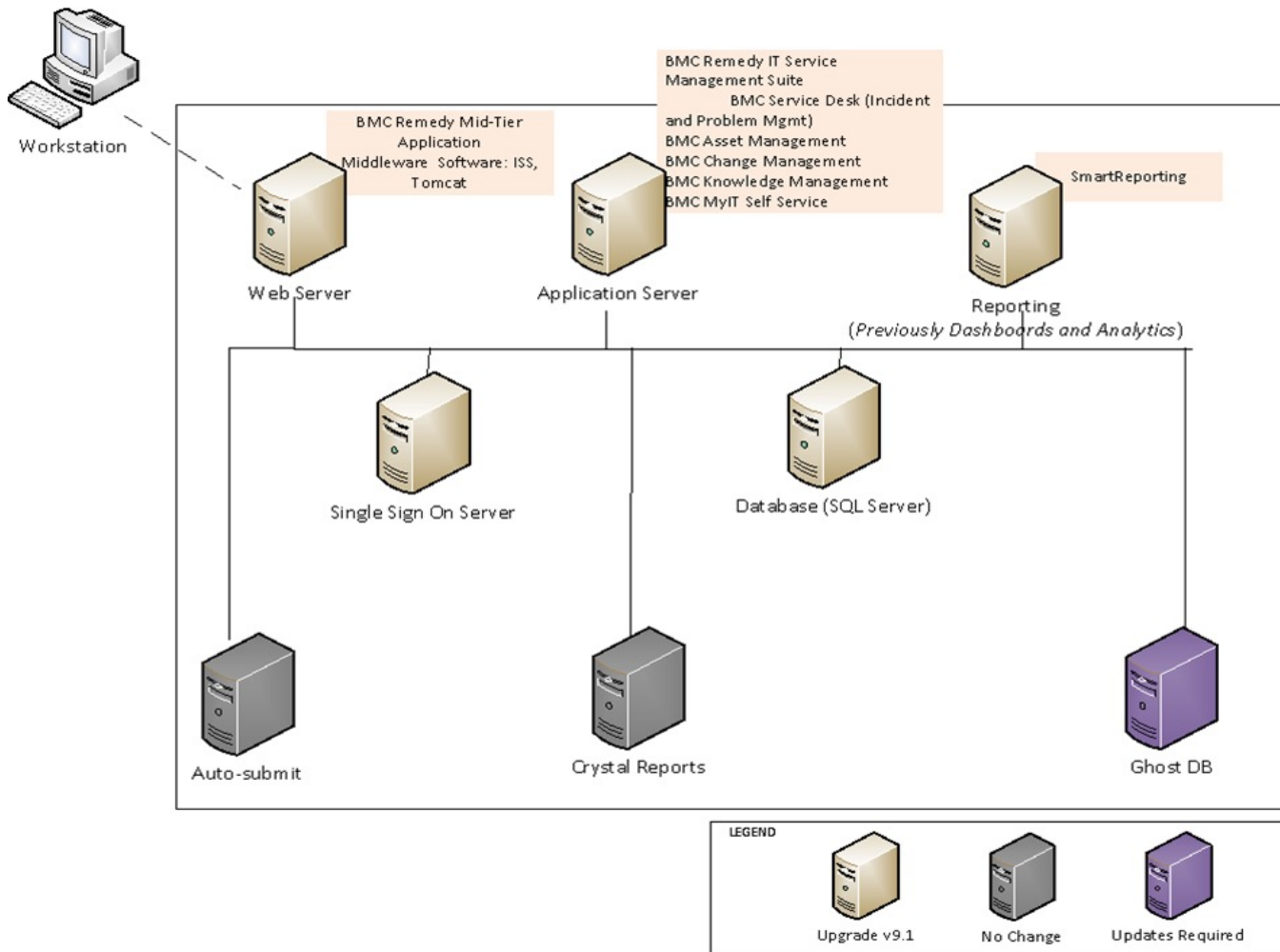

# SV-1/2 Hybrid Example

## Systems Interface Description (SV-1 & 2)

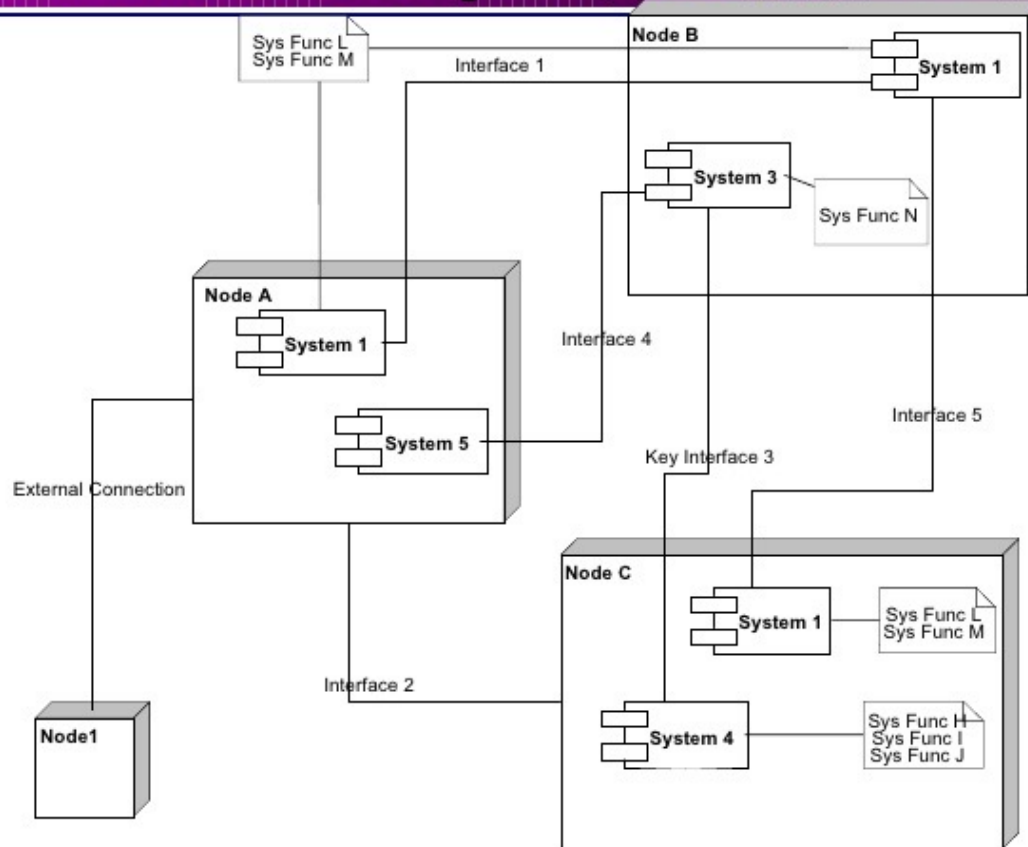

# SV-2 Example

## SV-2 System Communications Description

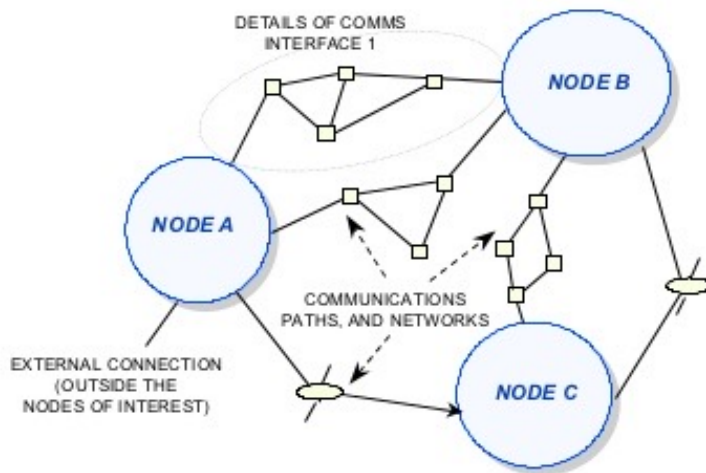

Internodal Perspective

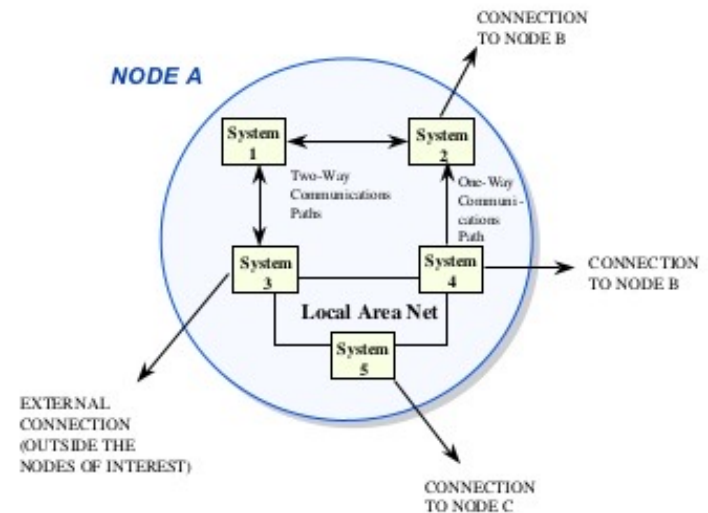

Intranodal Perspective

# SV-3 Example

## SV-3 System-System Matrix

	SYSTEM 1	SYSTEM 2	SYSTEM 3	SYSTEM 4	SYSTEM 5	SYSTEM 6	SYSTEM 7	SYSTEM 8	SYSTEM 9	SYSTEM 10
SYSTEM 1		●								
SYSTEM 2	●		●	●	●	●				
SYSTEM 3		●		●	●	●				
SYSTEM 4		●	●		●	●				
SYSTEM 5		●	●	●		●				
SYSTEM 6	●	●	●	●	●		●	●	●	●
SYSTEM 7						●				
SYSTEM 8						●				
SYSTEM 9						●				
SYSTEM 10						●				

# SV-4 Example 1

## SV-4 Systems Functionality Description

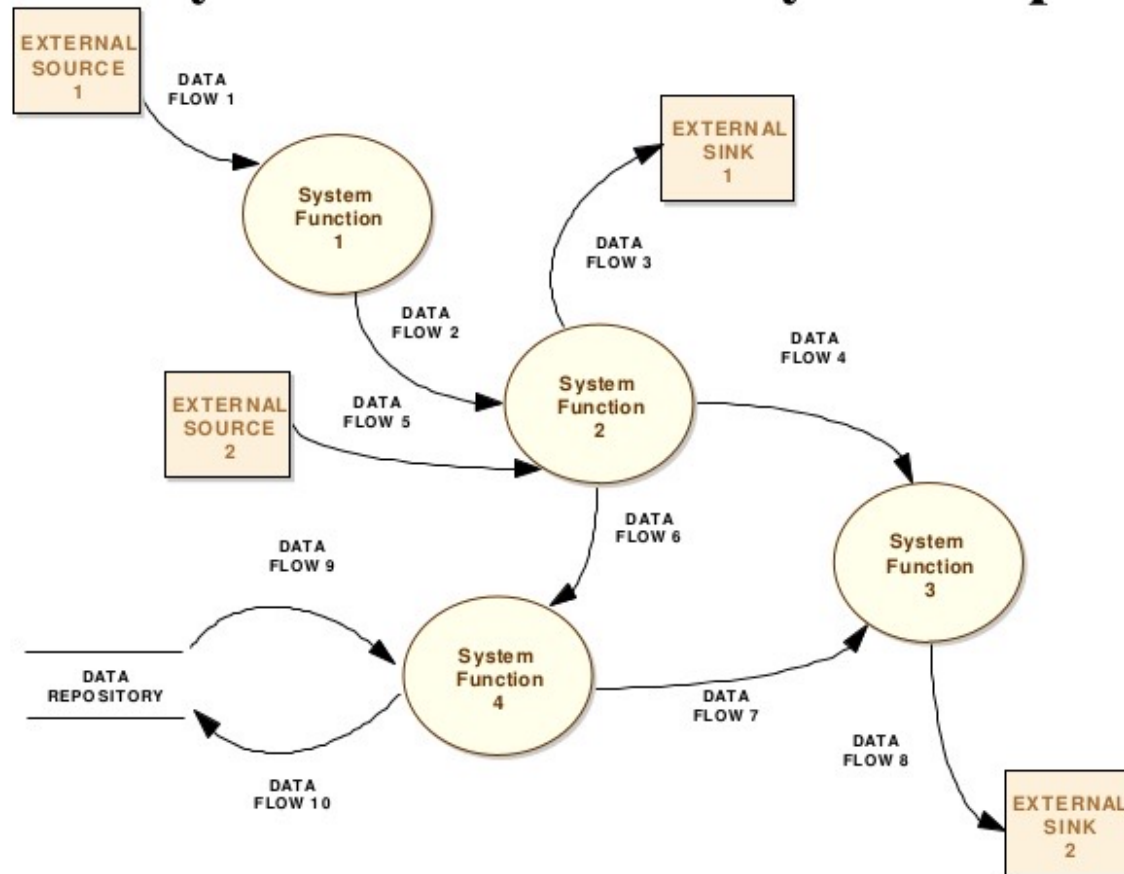

# SV-4 Example 2

## Systems Functionality Description (SV-4) Use Case Diagram – 1/3

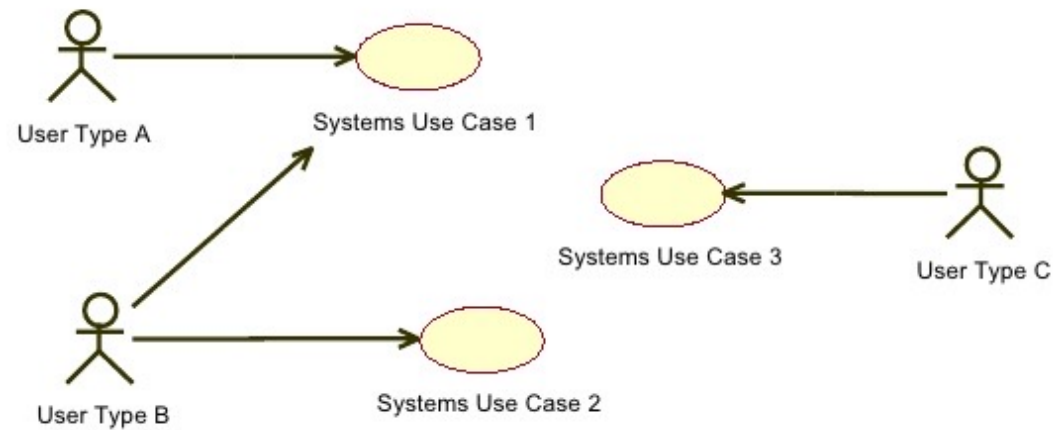

# SV-4 Example 3

## Systems Functionality Description (SV-4) Class Diagram – 2/3

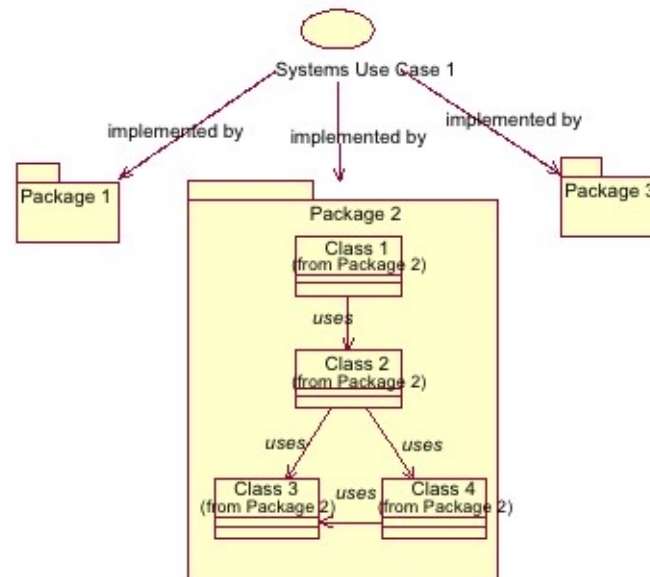

# SV-4 Example 4

## Systems Functionality Description (SV-4) Collaboration Diagram – 3/3

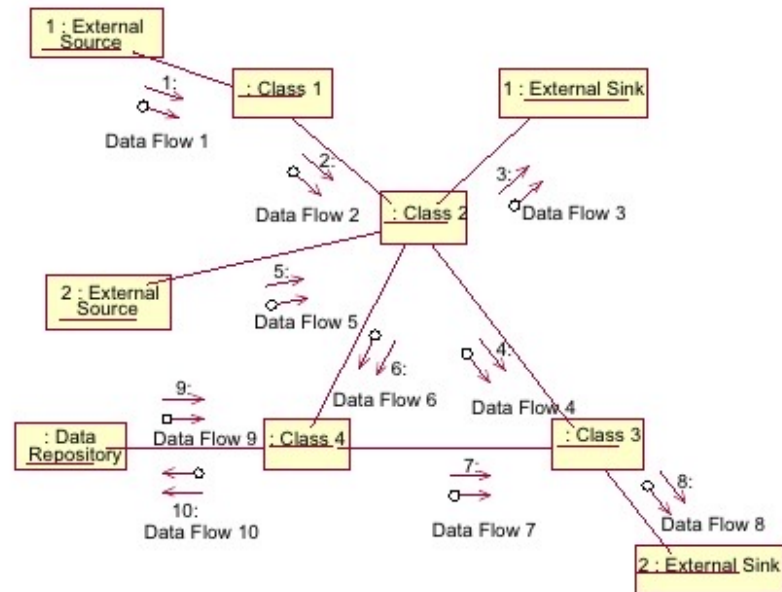

# SV-5 Example 1

## SV-5 Operational Activity to System Function Traceability Matrix

System Functions	Operational Activities																
	S.11	S.11.3	S.12	S.12.1	S.12.2	S.12.3	S.13	S.14	S.14.1	S.14.2	S.14.3	S.14.4	S.15	S.16	S.17	S.17.1	
1	X																
1.1		X															
1.1.1			X														
1.1.1.1	X																
1.1.1.2					X												
1.1.1.5							X										
1.1.2										X							
1.1.2.1				X													
1.1.2.2					X												
1.1.2.3								X									
1.1.3											X						
1.1.3.1														X			
1.1.3.2									X								
1.1.3.3															X		
1.1.3.4															X		



# SV-6 Example 1

## SV-6 System Data Exchange Matrix

Identifier/Name of Operational Needline Supported (from OV-2)	Identifier/Name of Corresponding System Interface(s) (from SV-1)	Identifier/Name of Operational Information Exchange Supported (from OV-3)	Identifier/Name of System Data Exchange	Nature of Transaction					Data Source		Data Destination	
				* Content	* Size	* Format	Other Protocols	LLSI Level Achievable	Source* System Name	Source System Component	Receiving* System Name	Receiving System Component
Needline 1	e.g., Interface 1	e.g., 1-a	e.g., 1-a (1)									
		e.g., 1-b	e.g., 1-a (n)									
	e.g., Interface 2	e.g., 1-c										
		e.g., 1-d										
	e.g., Interface n											
Needline 2												
⋮												
Needline n												

Identifier/Name of Operational Needline Supported (from OV-2)	Identifier/Name of Corresponding System Interface(s) (from SV-1)	Identifier/Name of Operational Information Exchange Supported (from OV-3)	Identifier/Name of System Data Exchange	Performance Attributes				Information Assurance Attributes				Threats			Physical Environment		
				* Propriety	* Timeliness	Throughput	Other	* Classification	* Criticality/Priority	* Encryption	* Authentication	Physical	Electronic	Political/Economic	Acrospace	Land	Sea
Needline 1	e.g., Interface 1	e.g., 1-a	e.g., 1-a (1)														
		e.g., 1-b	e.g., 1-a (n)														
	e.g., Interface 2	e.g., 1-c															
		e.g., 1-d															
	e.g., Interface n																
Needline 2																	
⋮																	
Needline n																	

DoDAF 2.0 refers to this diagram as the “Systems Resource Flow Matrix.” Either title seems acceptable, as long as the intent is clear.

# SV-6 Example 2, Part 1

## Systems Data Exchange Matrix (SV-6)

Interface Identification	Data Exchange Identification	Data Exchange Identification						Nature of Transaction		
Systems Interface Name and Identifier	Systems Data Exchange Name and Identifier	Content Description	Format Type	Media Type	Data Standard	Units of Measurement	Accuracy	Transaction Type	Triggering Event	Interoperability Level

# SV-6 Example 2, Part 2

## Systems Data Exchange Matrix (SV-6) Cont'd

Producer		Consumer		Performance Attributes			
Sending System Name and Identifier	Sending System Function Name and Identifier	Receiving System Name and Identifier	Receiving System Function Name and Identifier	Periodicity	Timeliness	Throughput	Size

Information Assurance								Security				
Access Control	Availability	Confidentiality	Dissemination Control	Criticality	Integrity	Non-Repudiation Producer	Non-Repudiation Consumer	Protection (Type Name, Duration, Date)	Classification	Classification Caveat	Release-ability	Security Standard

# SV-7 Example 1

## SV-7 System Performance Parameters Matrix

System Name	Refinement Threshold/Measures		
	Time <sub>0</sub> (Baseline)	Time <sub>1</sub>	Time <sub>0</sub> (Objective)
<b>Hardware Element 1</b>			
Maintainability			
Availability			
System Initialization Time			
Data Transfer Rate			
Program Restart Time			
<b>SW Element 1 / HW Element 1</b>			
Data Capacity (eg. throughput or # of input types)			
Automatic Processing Responses (by input type; # processed/unit time)			
Queue Interaction Response Times (by type)			
Effectiveness			
Availability			
Mean Time Between SW Failures			
Organic Training			
<b>SW Element 2 / HW Element 1</b>			
<b>Hardware Element 2</b>			

DoDAF 2.0 refers to this as the "Systems Measures Matrix."

# SV-7 Example 2

## Performance Parameters Matrix (SV-7)

System Name	Performance Thresholds/Measures		
	Time (Baseline)	Time	Time (Objective)
<b>Hardware Element 1</b>			
Maintainability			
Availability			
System Initialization Time			
Data Transfer Rate			
Program Restart Time			
<b>S/W Element 1 / H/W Element 1</b>			
Data Capacity (e.g., throughput or # of input types)			
Automatic Processing Responses (by input type, # processed/unit time)			
Operator Interaction Response Times (by type)			
Effectiveness			
Availability			
Mean Time Between S/W Failures			
Organic Training			
<b>S/W Element 2 / H/W Element 1</b>			
<b>Hardware Element 2</b>			

# SV-8 Example

## Systems Evolution Description (SV-8)

NEW FUNCTION 2 &  
UNIQUE DATA IMPLEMENTED  
ON CLIENT SERVER (& INTEGRATED WITH  
COMMON DATA ON MAINFRAME)

NEW FUNCTION 1 &  
UNIQUE DATA IMPLEMENTED  
ON CLIENT SERVER (& INTEGRATED WITH  
COMMON DATA ON MAINFRAME)

LEGACY  
MAINFRAME  
SYSTEM

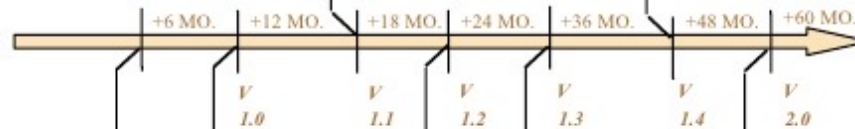

FEDERATED  
DISTRIBUTED  
SYSTEM

CLIENT/SERVER  
PLATFORMS, LAN, &  
MIDDLEWARE INSTALLED

SEGMENT 1 APPLICATIONS  
& UNIQUE DATA CONVERTED  
TO CLIENT/SERVER

SEGMENT 2 APPLICATIONS  
& UNIQUE DATA CONVERTED  
TO CLIENT/SERVER

SEGMENT 3 APPLICATIONS,  
& UNIQUE DATA CONVERTED  
TO CLIENT/SERVER

COMMON DATA CONVERTED  
TO SHARED DATA SERVER

# SV-9 Example 1

## SV-9 System Technology Forecast - Fragment -

TRM TECHNOLOGY CATEGORY	TECHNOLOGY FORECASTS		
	SHORT TERM (0-6 Months)	MID TERM (6-12 Months)	LONG TERM (12-18 Months)
<b>Application Software</b>			
<i>Support Applications</i>	Microsoft Office 2000 available (for Windows 2000)	Microsoft Office 2000 stable enough for full scale implementation	Microsoft Office available for Linux E-mail on wireless PDAs commonplace
<b>Application Platform</b>			
<i>User Interface Services</i>	Spoken interface support available		Spoken user interface becomes the standard user interface
Data Management	Oracle 9i available MySQL (Open Source DBMS) available		
Operating System		Next MS Windows desktop upgrade expected Next Red Hat Linux major release expected	Next MS Windows server upgrade expected
<i>Physical Environment</i>			Intel IA-64 becomes standard processor for desktops Initial use of quantum computing technologies

DoDAF 2.0 refers to this as the “Systems Technology & Skills Forecast.”

# SV-9 Example 2

## Systems Technology Forecast (SV-9)

TRM TECHNOLOGY CATEGORY	TECHNOLOGY FORECASTS		
	SHORT TERM (0-6 Months)	MID TERM (6-12 Months)	LONG TERM (12-18 Months)
<i>Application Software</i>			
Support Applications	Microsoft Office 2000 available (for Windows 2000)	Microsoft Office 2000 stable enough for full scale implementation	Microsoft Office available for Linux E-mail on wireless PDAs commonplace
<i>Application Platform</i>			
Data Management	Oracle 9i available MySQL (Open Source DBMS) available		
Operating System		Next MS Windows desktop upgrade expected Next Red Hat Linux major release expected	Next MS Windows server upgrade expected
Physical Environment			Intel IA-64 becomes standard processor for desktops Initial use of quantum computing technologies
<i>External Environment</i>			
User Interface		Thin screen CRT monitors for PC desktops become price competitive	Thin screen LED monitors become price competitive for desktops Conventional CRT technology monitors for desktops become obsolete
Persistent Storage	5G PCMCIA type 2 card available		Disk storage capacity doubles again
Networks		Cable modem service available for most telecommuting staff	Fiber optic connections available for most telecommuting staff

# SV-10b/10c Example

## SV-10 Systems Timing and Sequencing Products

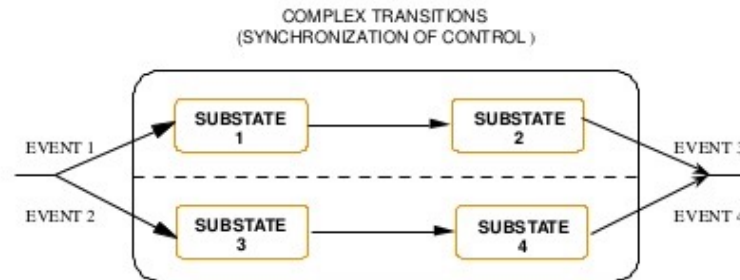

SV-10b Systems State Transition Description

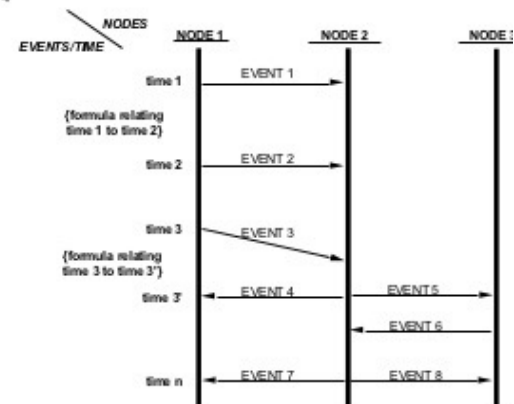

SV-10c Systems Event/Trace Description

# SV-11 Example

## SV-11 Physical Schema

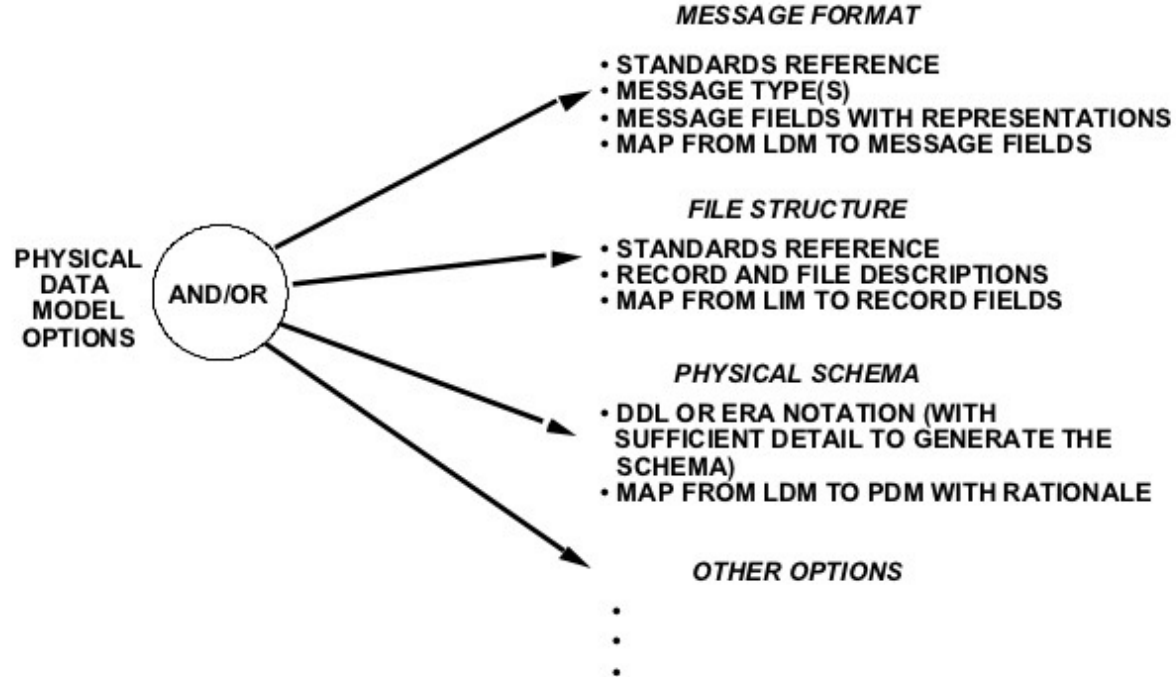

DoDAF 2.0 does not include this diagram, though it was part of DoDAF 1.5.

# References

# Useful References

- DoDAF Web Site – Very informative

<http://dodcio.defense.gov/Library/DoD-Architecture-Framework/>